

# 7 USER MANUAL FOR DP E161.CAN

---



## CONTENT

---

<b>7.1 Important Notice</b> .....	<b>2</b>	<b>7.6.1 Switching the System ON/OFF</b> .....	<b>5</b>
<b>7.2 Introduction of Display</b> .....	<b>2</b>	<b>7.6.2 Selection of Support Levels</b> .....	<b>5</b>
<b>7.3 Product Description</b> .....	<b>3</b>	<b>7.6.3 Headlights / backlighting</b> .....	<b>5</b>
7.3.1 Specifications.....	3	<b>7.6.4 Walk Assistance</b> .....	<b>5</b>
7.3.2 Functional Overview.....	3	<b>7.6.5 Battery Capacity Indication</b> .....	<b>6</b>
<b>7.4 Display</b> .....	<b>4</b>	<b>7.6.6 Bluetooth Function</b> .....	<b>6</b>
<b>7.5 Key Definition</b> .....	<b>4</b>	<b>7.7 Error Code Definition</b> .....	<b>7</b>
<b>7.6 Normal Operation</b> .....	<b>5</b>		

# 7.1 IMPORTANT NOTICE

---

- If the error information from the display cannot be corrected according to the instructions, please contact your retailer.
- The product is designed to be waterproof. It is highly recommended to avoid submerging the display under water.
- Do not clean the display with a steam jet, high-pressure cleaner or water hose.
- Please use this product with care.
- Do not use thinners or other solvents to clean the display. Such substances can damage the surfaces.
- Warranty is not included due to wear and normal use and aging.

# 7.2 INTRODUCTION OF DISPLAY

---

- Model: DP E161.CAN BUS
- The housing material is PC+ABS and acrylic, as following:



- The label marking is as follows:



**i** **Note:** Please keep the QR code label attached to the display cable. The information from the Label is used for a later possible software update.

# 7.3 PRODUCT DESCRIPTION

---

## 7.3.1 Specifications

- Operating temperature: -20 °C~45 °C
- Storage temperature: -20 °C~50 °C
- Waterproof: IP65
- Storage room Humidity: 30%-70% RH

## 7.3.2 Functional Overview

- Battery capacity indicator
- Indication of support level
- Walk assistance
- Automatic sensors explanation of the lighting system
- Indication for error messages
- Control and indication of lighting system
- Bluetooth function

# 7.4 DISPLAY

---

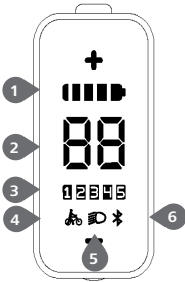

- 1 Battery capacity indicator
- 2 Speed indicator
- 3 Support level indicator
- 4 Walk assistance
- 5 Indicator for lighting system
- 6 Bluetooth indicator

# 7.5 KEY DEFINITION

---

E161 Display has three buttons: System On/Off , Up  and Down .

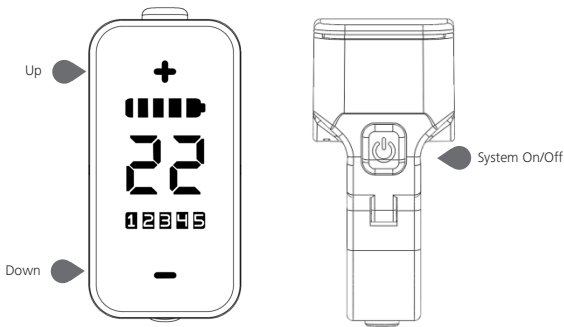

# 7.6 NORMAL OPERATION



## 7.6.1 Switching the System ON/OFF

Press and hold  (>2S) on the display to turn on the system.

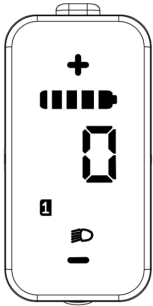
Press and hold  (>2S) again to turn off the system.



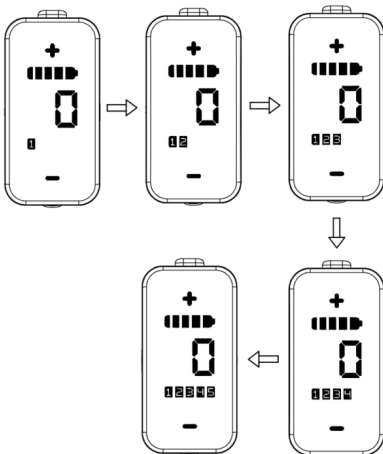

## 7.6.2 Selection of Support Levels

When the display is turned on, press the  or  (<0.5S) button to switch to the support level, the lowest level is 1, the highest level is 5. When the system is switched on, the support level starts in level 1. There is no support at level 0.





## 7.6.3 Headlights / backlighting

Hold the  (>2S) button to activate the headlight and taillights.

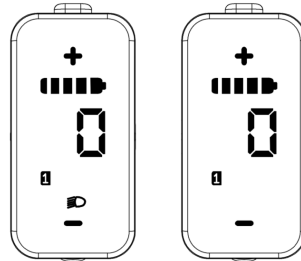
Hold the  (>2S) button again to turn off the headlight and taillight. (If the display is turned on in a dark environment, the display backlight/headlight will be turned on automatically. If the display backlight/headlight are turned off manually, they also need to be turned on manually afterwards)



## 7.6.4 Walk Assistance

When your Pedelec is motionless, briefly press  button until the Walk assistance indicator  is displayed. At this point, long press  button, the Pedelec enters the walk assistance mode, the indicator will flash. If release the button will stop this, if no any operations within 5s will automatically return to 0 level. That is stopped from the Walk assistance mode.(as following)

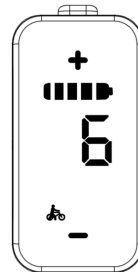

### 7.6.5 Battery Capacity Indication

The battery capacity is indicated with 5 levels. When the lowest level indicator flashes that means battery needs to charge. The battery capacity is shown as follows:

Indication definition	SOC	Example
5 bars	80%-100%	
4 bars	60%-80%	
3 bars	40%-60%	
2 bars	20%-40%	
1 bar	5%-20%	
1 flashing	<5%	

### 7.6.6 Bluetooth Function

When the mobile phone is connected to the display by Bluetooth, the Bluetooth symbol will be displayed, and the disconnected symbol will disappear automatically.

This display can be connected to the Bafang Go APP through Bluetooth. More information can be viewed on the APP, such as the information of battery, remaining capacity, single-trip distance.



# 7.7 ERROR CODE DEFINITION



DP E161.CAN display can provide warning for failures. The error code flickers when an error is detected.



**Note:** please read carefully the description of the error code. When the error code appears, please first restart the system. If the problem is not eliminated, please contact your dealer or technical personnel.

Error	Declaration	Troubleshooting
04	The throttle has fault.	<ol style="list-style-type: none"> <li>1. Check the connector of throttle whether they are correctly connected.</li> <li>2. Disconnect the throttle, If the problem still occurs, please contact your retailer. (only with this function)</li> </ol>
05	The throttle is not back in its correct position.	Check the throttle can adjust back into its correct position, if the situation does not improve, please change to a new throttle.(only with this function)
07	Overvoltage protection	<ol style="list-style-type: none"> <li>1. Remove the battery.</li> <li>2. Re-Insert the battery.</li> <li>3. If the problem persists, please contact your retailer.</li> </ol>
08	Error with the hall sensor signal inside the motor	Please contact your retailer.
09	Error with the Engine phase's	Please contact your retailer.
10	The temperature inside the engine has reached its maximum protection value	<ol style="list-style-type: none"> <li>1. Turn off the system and allow the Pedelec to cool down.</li> <li>2. If the problem persists, please contact your retailer.</li> </ol>
11	The temperature sensor inside the motor has an error	Please contact your retailer.
12	Error with the current sensor in the controller	Please contact your retailer.
13	Error with the temperature sensor inside of the battery	Please contact your retailer.

Error	Declaration	Troubleshooting
14	The protection temperature inside the controller has reached its maximum protection value	<ol style="list-style-type: none"> <li>1. Turn off the system and let the pedelec cool down.</li> <li>2. If the problem persists, please contact your retailer.</li> </ol>
15	Error with the temperature sensor inside the controller	Please contact your retailer.
21	Speed sensor Error	<ol style="list-style-type: none"> <li>1. Restart the system</li> <li>2. Check that the magnet attached to the spoke is aligned with the speed sensor and that the distance is between 10 mm and 20 mm.</li> <li>3. Check that the speed sensor connector is connected correctly.</li> <li>4. If the error persists, please contact your retailer.</li> </ol>
25	Torque signal Error	<ol style="list-style-type: none"> <li>1. Check that all connections are connected correctly.</li> <li>2. If the error persists, please contact your retailer.</li> </ol>
26	Speed signal of the torque sensor has an error	<ol style="list-style-type: none"> <li>1. Check the connector from the speed sensor to make sure it is connected correctly.</li> <li>2. Check the speed sensor for signs of damage.</li> <li>3. If the problem persists, please contact your retailer.</li> </ol>
27	Overcurrent from controller	Please contact your retailer.
30	Communication problem	<ol style="list-style-type: none"> <li>1. Check all connections are correctly connected.</li> <li>2. If the error persists, please contact your retailer.</li> </ol>
33	Brake signal has an error (If brake sensors are fitted)	<ol style="list-style-type: none"> <li>1. Check all connectors.</li> <li>2. If the error continues to occur, please contact your retailer.</li> </ol>



Error	Declaration	Troubleshooting
35	Detection circuit for 15V has an error	Please contact your retailer.
36	Detection circuit on the keypad has an error	Please contact your retailer.
37	WDT circuit is faulty	Please contact your retailer.
41	Total voltage from the battery is too high	Please contact your retailer.
42	Total voltage from the battery is too low	Please contact your retailer.
43	Total power from the battery cells is too high	Please contact your retailer.
44	Voltage of the single cell is too high	Please contact your retailer.
45	Temperature from the battery is too high	Please contact your retailer.
46	The temperature of the battery is too low	Please contact your retailer.
47	SOC of the battery is too high	Please contact your retailer.
48	SOC of the battery is too low	Please contact your retailer.
61	Switching detection defect	Please contact your retailer. (only with this function)
62	Electronic derailleur cannot release	Please contact your retailer. (only with this function)
71	Electronic lock is jammed	Please contact your retailer. (only with this function)
81	Bluetooth module has an error	Please contact your retailer. (only with this function)